

MEDIUM DUTY DOOR OPERATOR

MODELS MJ5011U, MH5011U, MHS5011U, & MGJ5011U

INSTALLATION MANUAL

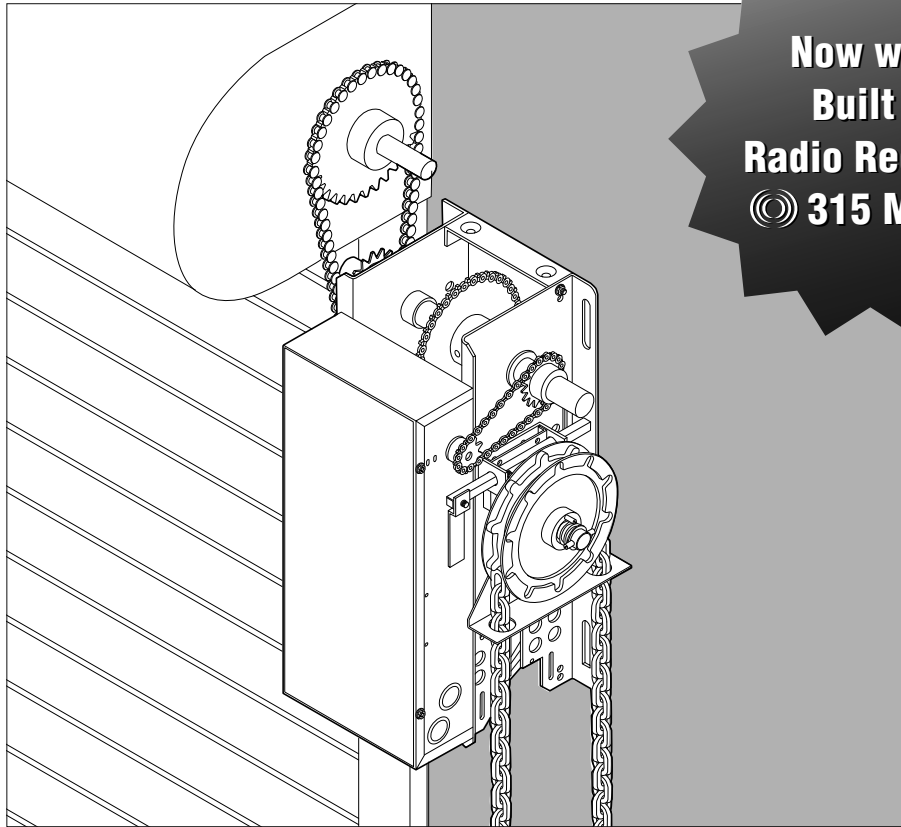

**Now with
Built in
Radio Receiver
315 MHz**

Your model may look different than the model illustrated in this manual.

2 YEAR WARRANTY

Serial # _____
(located on electrical box cover)

Installation Date _____

**THIS PRODUCT IS TO BE
INSTALLED AND SERVICED BY A
TRAINED DOOR SYSTEMS
TECHNICIAN ONLY.**

Visit www.liftmaster.com to locate a professional installing dealer in your area.

OPERATOR RATING: 12 cycles per hour,
50 cycles per day; maximum

NOT FOR RESIDENTIAL USE



TABLE OF CONTENTS

SAFETY INFORMATION	3
APPLICATION	4
OPERATOR SPECIFICATIONS	5-6
Weights and Dimensions	5
Motor	6
Mechanical	6
Electrical	6
Safety	6
Environmental	6
CARTON INVENTORY	6
PREPARATION	7
Preparing Your Door	7
Handing Identification	7
ASSEMBLY	7
TYPICAL INSTALLATION	8-14
Determine Mounting Location for Operator	8
Install the Operator	8-9
Install Emergency Disconnect System	10
Power and Ground Wiring Connections	11-12
Install 3-Button Control Station	12-13
Setup Radio Antenna	13-14
ADJUSTMENT	15
Adjust the Limits	15
Adjust the Clutch	15
ENTRAPMENT PROTECTION	16-19
LiftMaster Monitored Entrapment Protection (LMEP)	16
Install the Photoelectric Sensors (Provided)	17
Mount the Photoelectric Sensors	18
Entrapment Protection Wiring Options	18-19
LOGIC BOARD LAYOUT	19
BASIC PROGRAMMING	20-23
Determine the Wiring Type	20-21
Remote Controls	21-22
Timer-to-Close (TTC)	22-23
TESTING	23
EMERGENCY DISCONNECT	24
TROUBLESHOOTING	25-26
DIAGRAM	26
ACCESSORIES	27
CONTROL CONNECTION DIAGRAM	BACK COVER

SAFETY INFORMATION

WARNING

Mechanical

WARNING

Electrical

When you see these Safety Symbols and Signal Words on the following pages, they will alert you to the possibility of **serious injury** or **death** if you do not comply with the warnings that accompany them. The hazard may come from something mechanical or from electric shock. Read the warnings carefully.

CAUTION

When you see this Signal Word on the following pages, it will alert you to the possibility of damage to your door and/or the door operator if you do not comply with the cautionary statements that accompany it. Read them carefully.

IMPORTANT NOTES:

- *BEFORE attempting to install, operate or maintain the operator, you must read and fully understand this manual and follow all safety instructions.*
- *DO NOT attempt repair or service of your commercial door and gate operator unless you are an Authorized Service Technician.*

IMPORTANT INSTALLATION INSTRUCTIONS

WARNING

To reduce the risk of SEVERE INJURY or DEATH:

1. READ AND FOLLOW ALL INSTALLATION WARNINGS AND INSTRUCTIONS.
2. Install door operator ONLY on properly balanced and lubricated door. An improperly balanced door may not reverse when required and could result in SEVERE INJURY or DEATH.
3. ALL repairs to cables, spring assemblies and other hardware MUST be made by a trained door systems technician BEFORE installing operator.
4. Disable ALL locks and remove ALL ropes connected to door BEFORE installing operator to avoid entanglement.
5. Install door operator 8 feet (2.44 m) or more above floor.
6. NEVER connect door operator to power source until instructed to do so.
7. NEVER wear watches, rings or loose clothing while installing or servicing operator. They could be caught in door or operator mechanisms.
8. Install control station:
 - within sight of the door.
 - out of reach of children at minimum height of 5 feet (1.5 m).
 - away from ALL moving parts of the door.
9. Install the control station far enough from the door to prevent the user from coming in contact with the door while operating the controls.
10. Install the entrapment warning placard on wall next to the control station in a prominent location that is visible from the door.
11. Place manual release/safety reverse test label in plain view on inside of door.
12. Upon completion of installation, test entrapment protection device.
13. **SAVE THESE INSTRUCTIONS.**

APPLICATION

This operator includes a number of features that will provide years of reliable and safe operation.

FEATURES:

- **Supports both monitored and non-monitored entrapment protection devices:** Entrapment protection devices detect obstructions in the door's path and automatically reverse a closing door.
- **Radio receiver:** A factory installed radio receiver allows remote controls, keyless entries and other remote command devices to be programmed to the operator.
- **Timer-To-Close:** The Timer-to-Close feature allows the door to automatically close after a preset time (only available with B2 wiring and a monitored entrapment protection device).
- **Wiring Types:** The functionality of the operator is based on the wiring type. The operator is shipped from the factory in standard C2 wiring type (factory default). Some wiring types will require an optional monitored entrapment protection device. Refer to Basic Programming Section for descriptions of wiring types, requirements and programming.

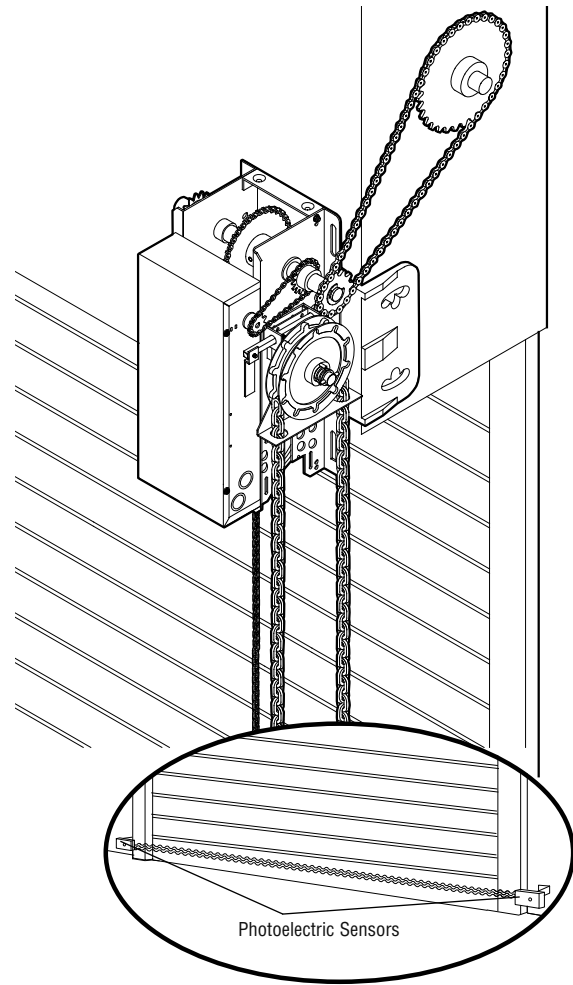

Intended for use on vertical or high-lift sectional doors, or rolling door products. The MHS operator is recommended for rolling sheet doors. **Not recommended for use on a standard lift sectional door.**

MAXIMUM DOOR AREA (SQ. FEET)						
ROLLING DOOR	24 ga. Steel	22 ga. Steel	---	20 ga. Steel 18 ga. Steel	16 ga. Steel	
	Aluminum Grilles	Aluminum Doors	---	---		
	---	24 ga. Steel	20 ga. Steel	---	20 ga. Steel Insulated	16 ga. Steel Insulated
SECTIONAL DOOR	---	24 ga. 22 ga. Steel	20 ga. Steel	---	16 ga. Steel	---
	Fiberglass	Aluminum Doors	Wood Doors	---	---	---
	---	---	24 ga. Steel Insulated	---	20 ga. Steel Insulated	16 ga. Steel Insulated
SQ. FT	320	275	250	200	160	120

NOTE: On steel insulated doors, a 24 ga. Back panel is assumed.

OPERATOR SPECIFICATIONS

WEIGHTS AND DIMENSIONS

MODELS MH, MJ, AND MHS

Hanging Weight: 60-70 LBS. (27.22-31.75 kg)

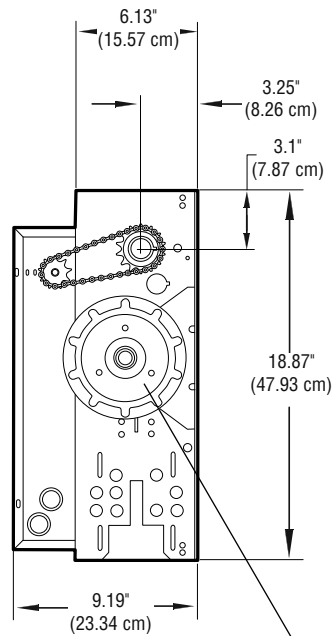
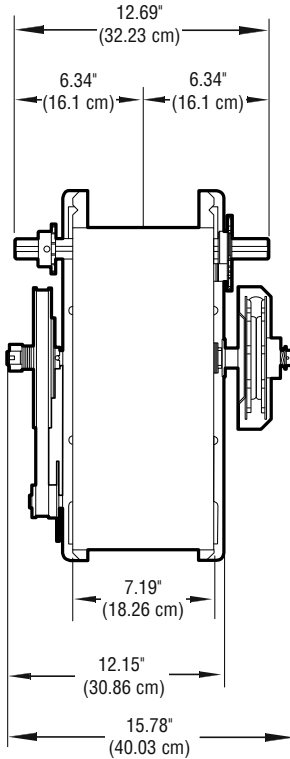

Hand Chain Wheel present with Model MH only.

MOUNTING DIMENSIONS

- A - Wall Mounting
- B - Bracket Mounting (rolling door)

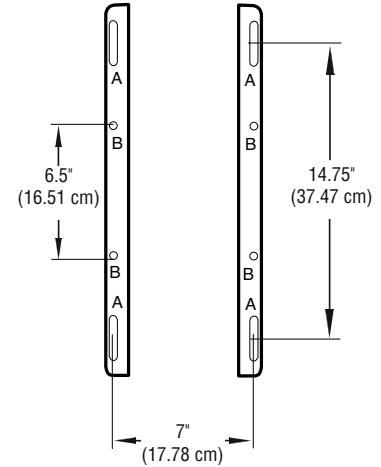

MODEL MGJ ONLY

Hanging Weight: 60 LBS. (27.22 kg)

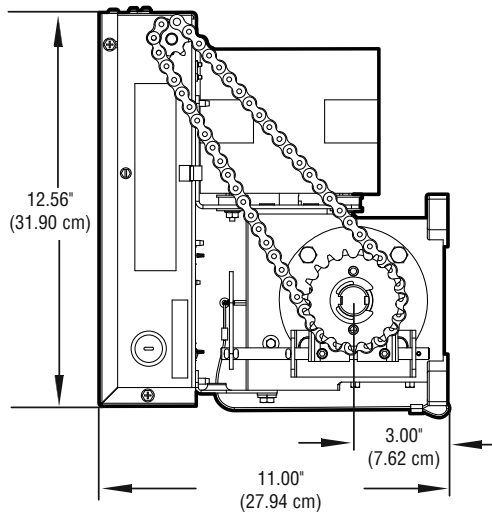
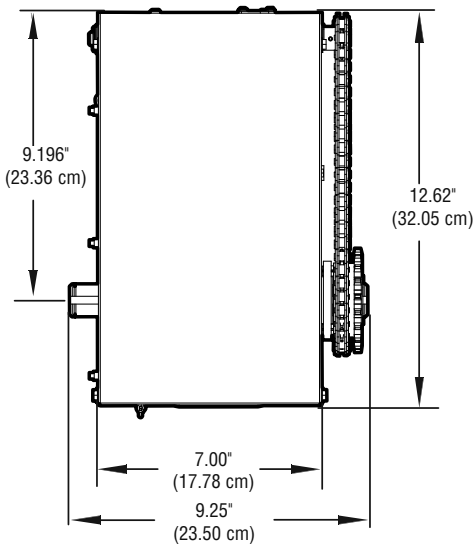

MOUNTING DIMENSIONS

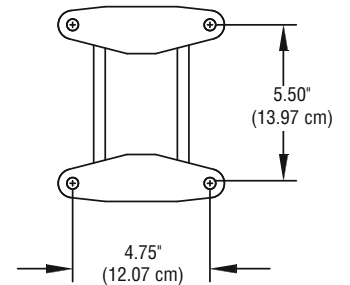

OPERATOR SPECIFICATIONS

MOTOR

TYPE: Limited duty
 HORSEPOWER: 1/2 HP
 VOLTAGE: 115 Vac, Single Phase, 60 Hz
 FULL LOAD AMPS: 6.0 Amps

MECHANICAL

DOOR SPEED: Approximately 9" (23 cm) / second
 depending on door setup
 OUTPUT FORCE: 125 ft. lbs / sec.
 MGJ ONLY 40 ft. lbs / sec.
 OUTPUT RPM:
 MJ 80 RPM
 MH 80 RPM
 MHS 38.6 RPM
 MGJ 23 RPM
 LIMIT ADJUST: Fully adjustable up to 14' door Max
 DUTY: 12 Cycles per Hour Max
 50 Cycles per Day Max
 DRIVE TRAIN: Maintenance Free Bearings
 MGJ ONLY Maintenance Free Bearings
 Wormgear-in-Oil-Bath Reducer
 FINISH: Powder coated, Corrosion Resistant Steel

ELECTRICAL

OPERATOR VOLTAGE: 115 Vac, Single Phase, 60 Hz
 WIRING TYPE: C2 (Standard) B2 Configurable
 (See Basic Programming Section)
 CONTROL WIRING: 16-22 AWG

SAFETY

DISCONNECT:

MH Floor level chain hoist for
 manual chain hoist operation.
 MJ Floor level disconnect for
 manual operation.
 MHS Both MH and MJ type disconnects described above.
 MGJ Floor level disconnect for
 manual operation.

ENTRAPMENT PROTECTION:

LiftMaster Monitored Entrapment Protection (LMEP)

Photoelectric Sensors (CPS-U): Through beam
 used to provide non-contact safety protection.
 Safety Edge (Optional): Electric or pneumatic sensing
 device attached to the bottom edge of door.
 (see Accessory Page 27)

ENVIRONMENTAL

LOCATION: Indoor, dry location
 OPERATING TEMPERATURE: -4° F to + 122° F
 (-20° C to + 50° C)
 UL Listed to 40° C: Chamberlain tested to 50° C

CARTON INVENTORY

Before beginning your installation check that all components were provided. Your model may look different than the model illustrated.

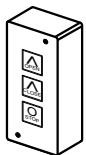

3-Button Station

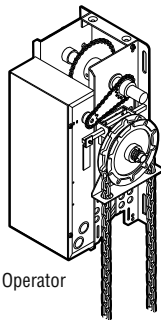

Operator



Warning Placard

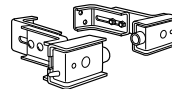

LiftMaster Monitored Entrapment Protection (LMEP)
 Model CPS-U



Operator Drive
 Sprocket



Door/Operator
 Chain

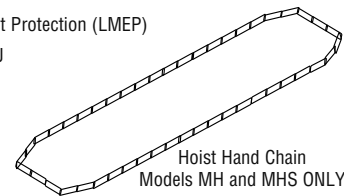

Hoist Hand Chain
 Models MH and MHS ONLY

NOT SHOWN

Installation Manual
 Quickstart Guide
 User's Guide
 Entrapment Warning Placard
 Installation Hardware Bag, Complete with: Master links (2), Wall bracket (1), Fastener Bag (1)
 Door sprocket

PREPARATION

PREPARING YOUR DOOR

The manufacturer recommends 3 feet (91.4 cm) of clearance in front of operator for serviceability. Before you begin:

- Disable locks.
- Remove any ropes connected to door.
- Before the operator is installed, be sure the door has been properly aligned and is working smoothly. Although each installation will vary due to particular building characteristics, refer to the following general procedures to install the operator.

HANDING IDENTIFICATION

For MH and MHS models with manual hoist hand chain systems, the handing of the operator must be determined at the time of order. The handing is indicated by last letter of the model name (R or L). The illustration shown is a right-handed operator for models MJ and MHS series only. Left-handed operator will have hoist chain on the left side.

The hand chain wheel can not be switched on site. If your installation causes the hand chain to hang in the door opening, hook the chain off to the side near the top of the door jamb.

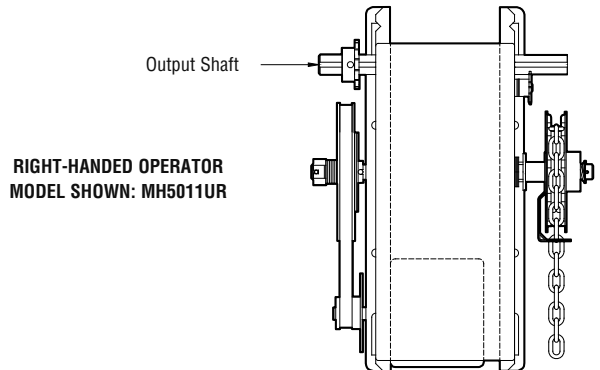

ASSEMBLY

- 1 Install operator drive sprocket.

RIGHT-HAND ASSEMBLY

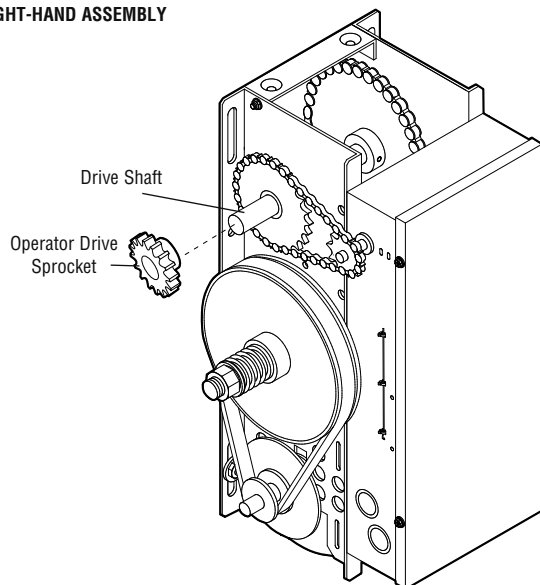

LEFT-HAND ASSEMBLY

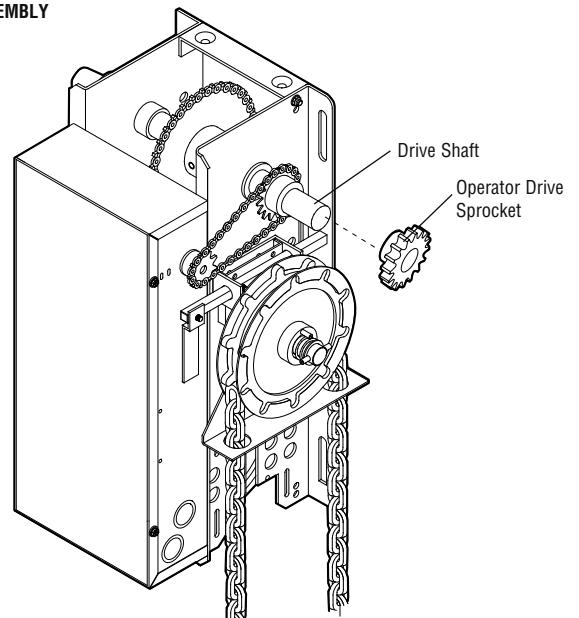

TYPICAL INSTALLATION

NOTE: The illustrations may not depict your installation.

DETERMINE MOUNTING LOCATION FOR OPERATOR

The operator may be mounted on the wall, shelf or bracket (not provided, see accessories or door manufacturer). The optimum distance between the door shaft and operator drive shaft is 12-15 inches.

WALL MOUNT

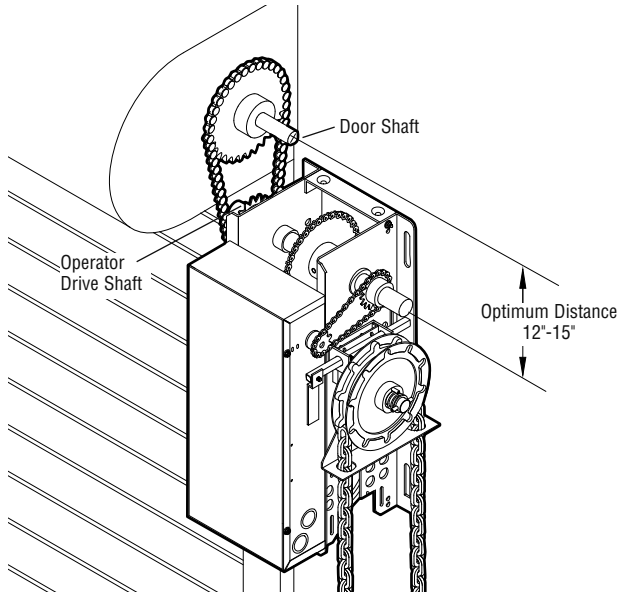

SHELF OR BRACKET MOUNTING

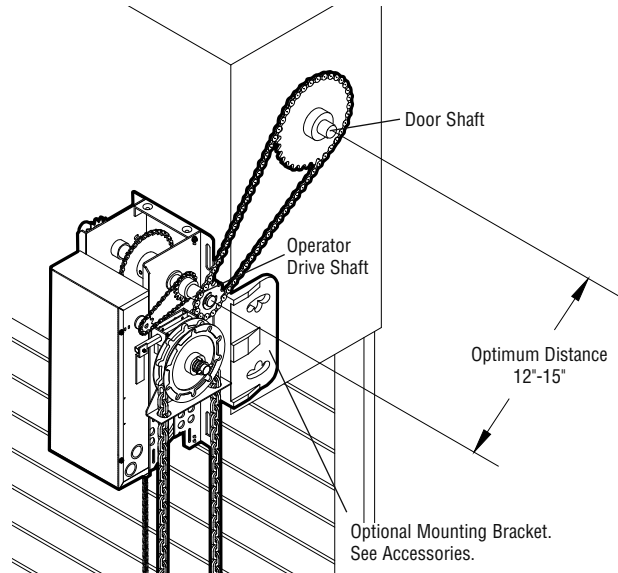

INSTALL THE OPERATOR

1 Place door sprocket on door shaft.

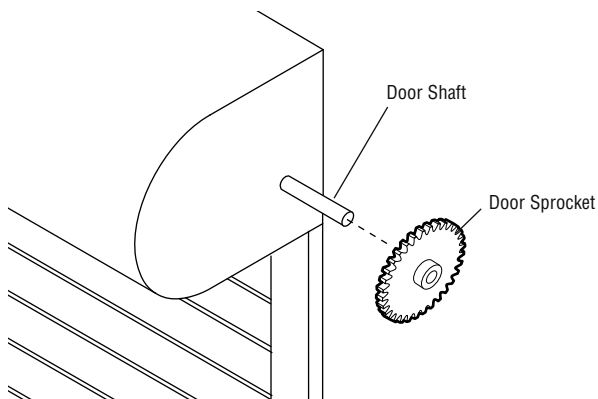

2 Place operator door sprocket on operator.

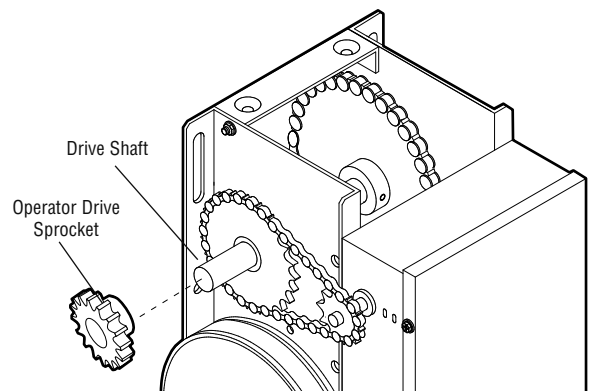

TYPICAL INSTALLATION

INSTALL THE OPERATOR

3 Wrap drive chain around door sprocket.

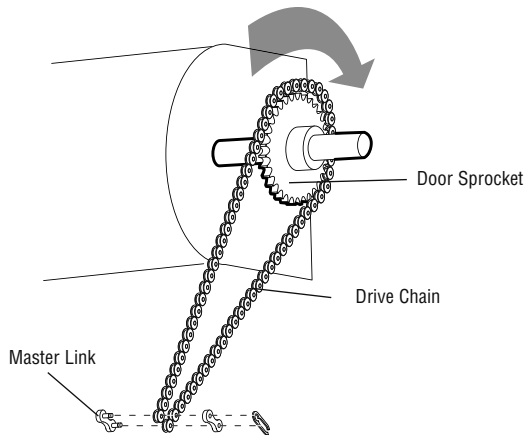

4 Wrap drive chain around operator sprocket.

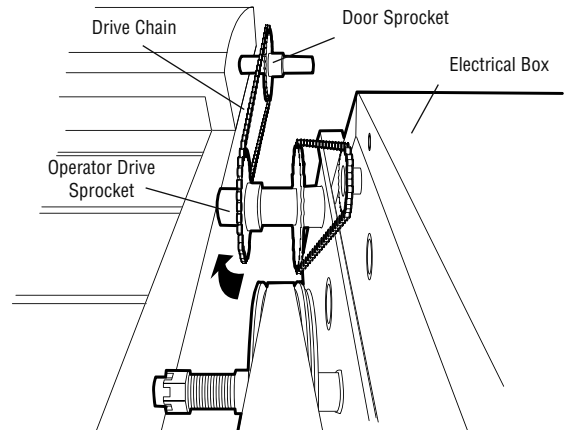

5 Position the operator until chain is taut (not tight). If chain is too tight, it may cause damage to operator.

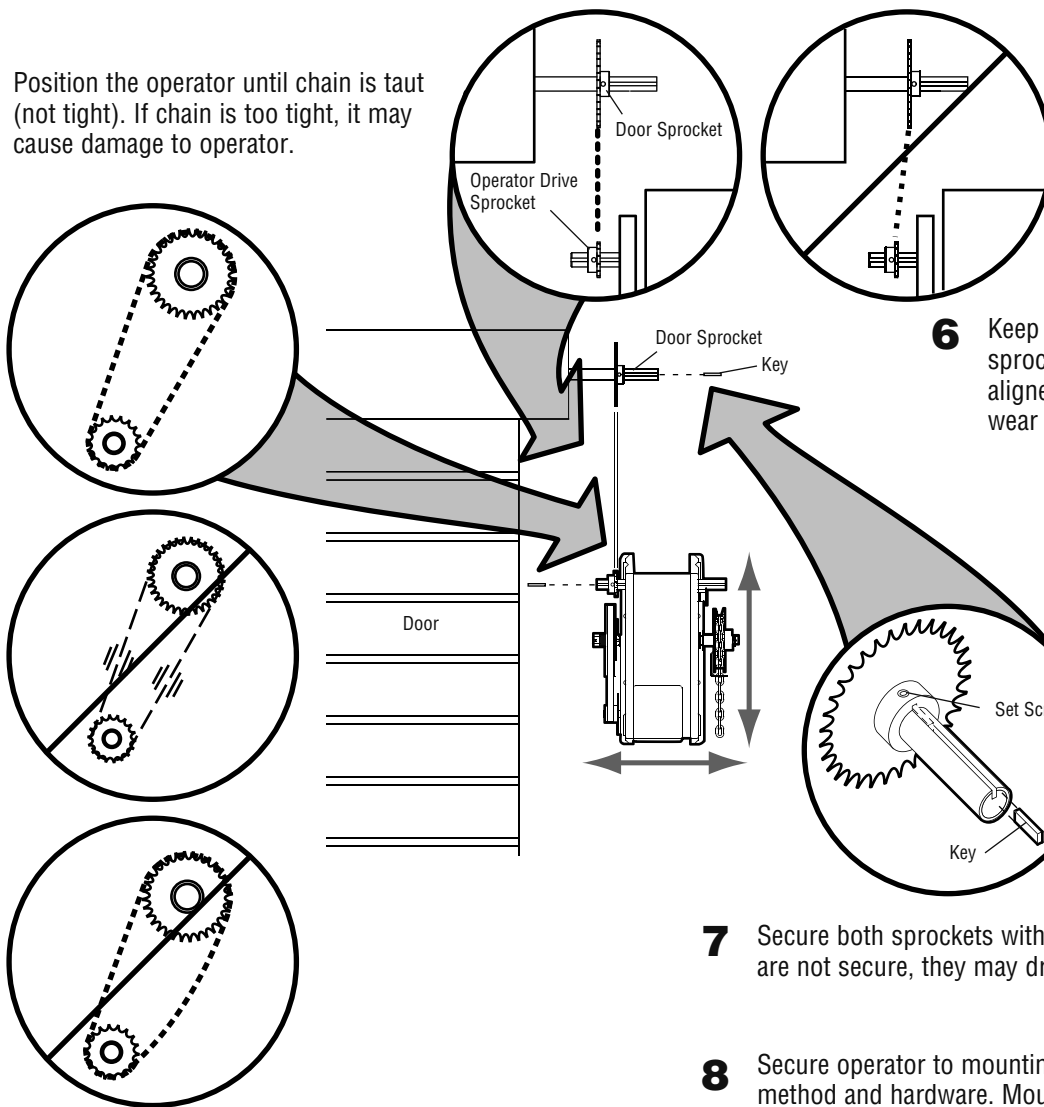

6 Keep door sprocket and operator door sprocket aligned. If sprockets are not aligned, they may cause premature wear on the chain.

7 Secure both sprockets with key and set screw. If sprockets are not secure, they may drift and cause damage to operator.

8 Secure operator to mounting surface using appropriate method and hardware. Mounting template can be found on carton.

TYPICAL INSTALLATION

INSTALL EMERGENCY DISCONNECT SYSTEM

MODELS MH AND MHS ONLY

The MHS operator includes both a floor level disconnect sash chain to disconnect the door from the door operator that allows manual push up operation and an additional sash chain to engage the manual chain hoist that also electrically disables the operator controls.

- 1 Secure chain retaining bracket to wall 4 feet above the floor.
- 2 Wrap hand chain around hand chain wheel and through chain guide.
- 3 Connect the ends of the hand chain.

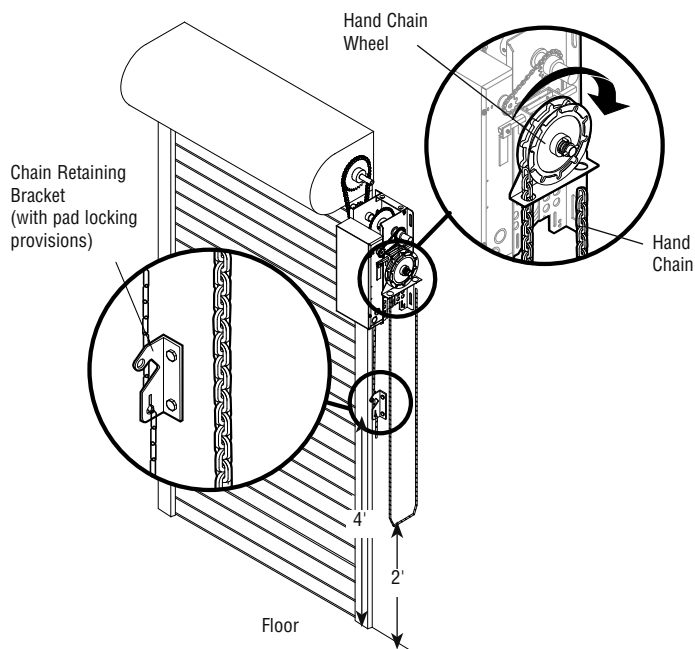

MODELS MJ AND MGJ ONLY

- 1 Secure keyhole bracket to wall 4 feet above the floor.

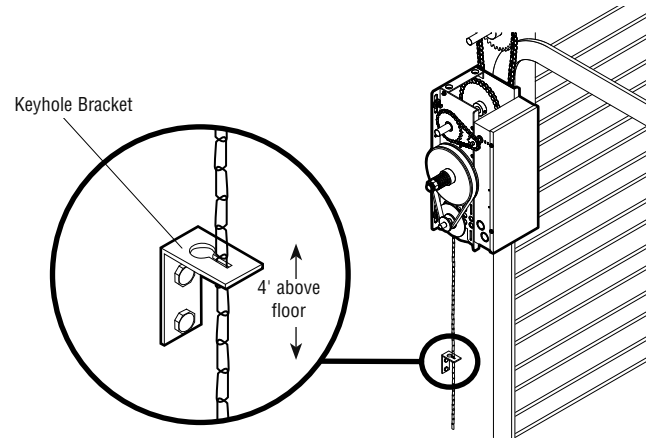

TYPICAL INSTALLATION

POWER AND GROUND WIRING CONNECTIONS

WARNING

To reduce the risk of SEVERE INJURY or DEATH:

- ANY maintenance to the operator or in the area near the operator MUST NOT be performed until disconnecting the electrical power and locking-out the power. Upon completion of maintenance the area MUST be cleared and secured, at that time the unit may be returned to service.
- Disconnect power at the fuse box BEFORE proceeding. Operator MUST be properly grounded and connected in accordance with local electrical codes. The operator should be on a separate fused line of adequate capacity.
- ALL electrical connections MUST be made by a qualified individual.
- DO NOT install ANY wiring or attempt to run the operator without consulting the wiring diagram.
- ALL power wiring should be on a dedicated circuit and well protected. The location of the power disconnect should be visible and clearly labeled.
- ALL power and control wiring MUST be run in separate conduit.

NOTE: Power and control wiring must be run in separate conduit in accordance with national and local electrical codes. Must use 14 AWG or heavier wire for power wiring. Use conduit knockouts for wiring as indicated on the electrical box labels.

IMPORTANT NOTE: Operator must be properly grounded. Failure to properly ground the operator could result in electric shock and serious injury.

DO NOT turn power on until you have finished making ALL power and control wiring connections.

POWER WIRING CHART

DISTANCE	GAUGE
50 feet	14 AWG
100 feet	12 AWG
200 feet	8 AWG*
350 feet	6 AWG*
500 feet	4 AWG*
1000 feet	2 AWG*

* Maximum wire gauge that can be connected to the operator's terminal is 12 AWG. When a larger wire gauge is required, the wire must be gauged down to 12 AWG. USE COPPER WIRE ONLY.

- 1 Remove cover.

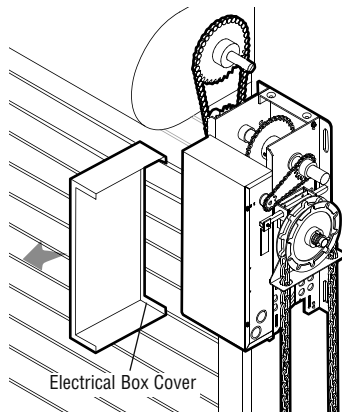

- 2 Run power wires to electrical box according to national and local electrical codes.

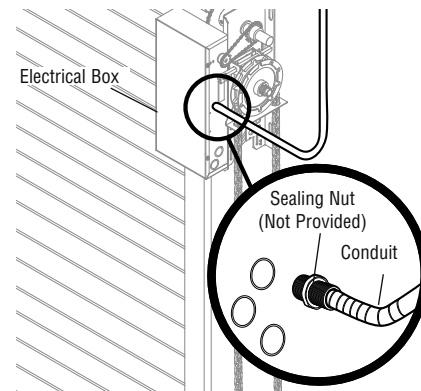

TYPICAL INSTALLATION

POWER AND GROUND WIRING CONNECTIONS

- 3** Attach power and ground wires to terminals.

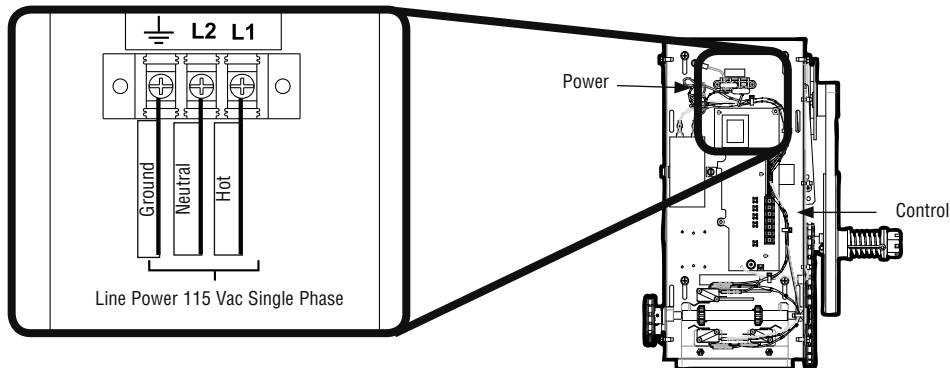

INSTALL 3-BUTTON CONTROL STATION

WARNING

To prevent possible **SERIOUS INJURY** or **DEATH** from electrocution:

- Be sure power is not connected **BEFORE** installing door control.

To prevent possible **SERIOUS INJURY** or **DEATH** from a closing door:

- Install door control within sight of door, out of reach of children at a minimum height of 5 feet (1.5 m) and away from **ALL** moving parts of door.
- Install the control station far enough from the door to prevent the user from coming in contact with the door while operating the controls.

- Install the entrapment warning placard on wall next to the control station in a prominent location that is visible from the door.
- **NEVER** permit children to operate or play with door control push buttons or remote controls.
- Activate door **ONLY** when it can be seen clearly, is properly adjusted and there are no obstructions to door travel.
- **ALWAYS** keep door in sight until completely closed. **NEVER** permit anyone to cross path of closing door.

- 1** Remove the control station cover.
2 Fasten the control station to the wall at least 5 feet above the ground. **The installation surface must be smooth and flat.**

- 3** Select appropriate knockout and run the wires to the operator.

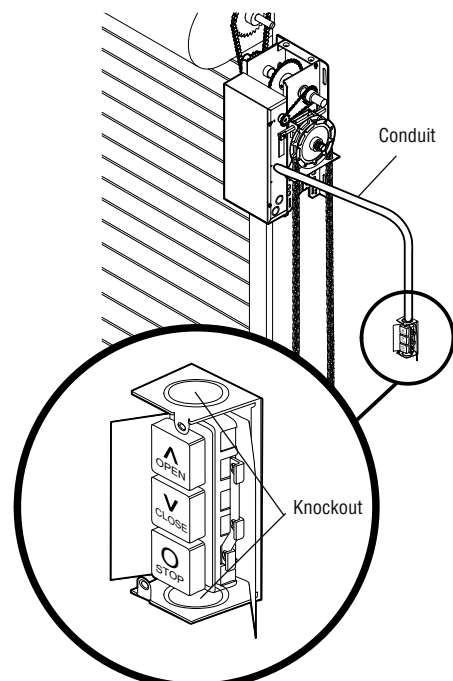
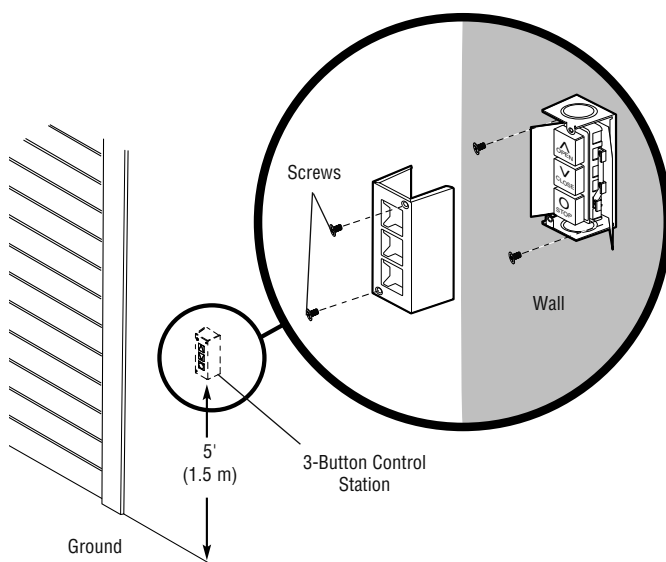

TYPICAL INSTALLATION

INSTALL 3-BUTTON CONTROL STATION

4 Connect wires to the control station and replace the control station cover.

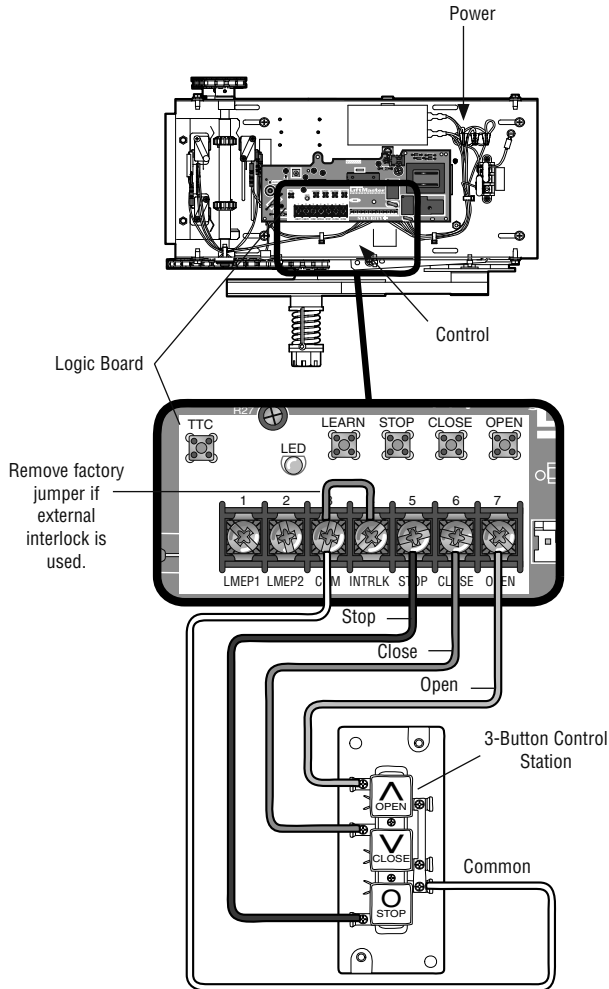

5 Fasten the entrapment warning placard next to the control station.

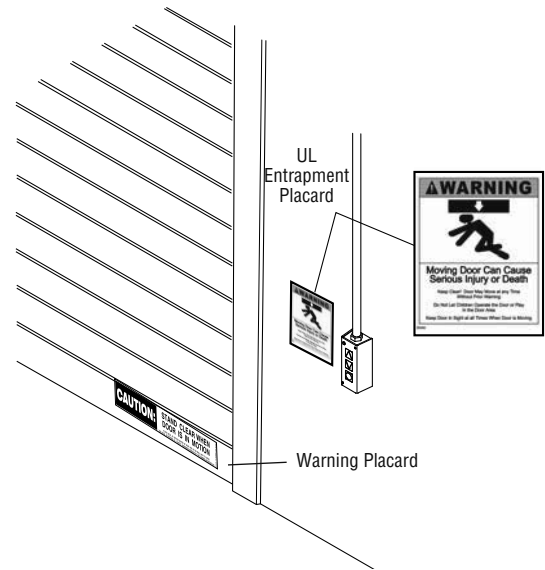

SETUP RADIO ANTENNA

OPTION A

1 Locate the wire antenna on the outside of the electrical box. Cut the wire tie closest to the edge of the electrical box.

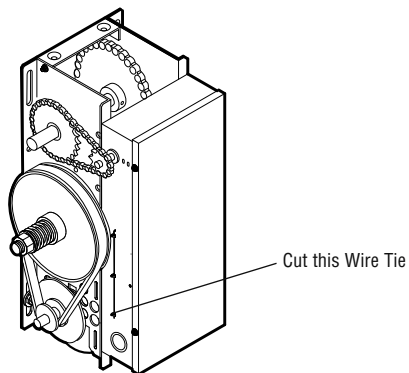

2 Press the plastic standoff into the hole in the side of the electrical box.

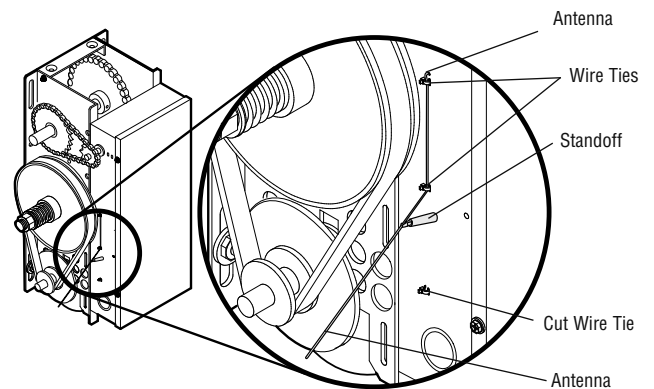

TYPICAL INSTALLATION

SETUP RADIO ANTENNA

OPTION B

- 1 Locate the wire antenna on the outside of the electrical box. Cut wire ties and discard standoff.

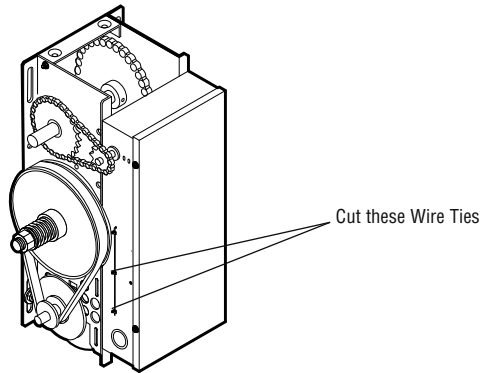

- 2 Attach the antenna to the electrical box using the wire tie holes. Bend antenna across the front of the electrical box, ensuring that the antenna is 4 inches away from the front of the electrical box.

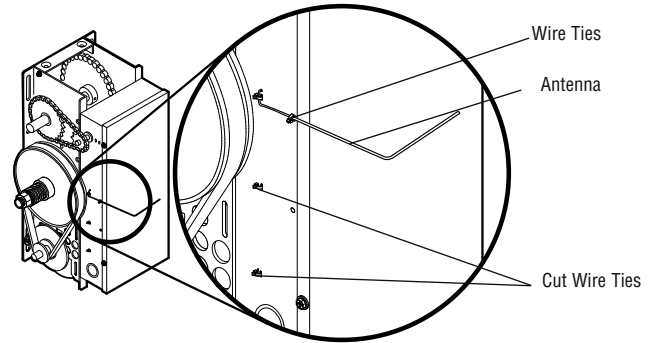

NOTICE: To comply with FCC and or Industry Canada (IC) rules, adjustment or modifications of this receiver and/or transmitter are prohibited, except for changing the code setting or replacing the battery. THERE ARE NO OTHER USER SERVICEABLE PARTS.

Tested to Comply with FCC Standards FOR HOME OR OFFICE USE. Operation is subject to the following two conditions: (1) this device may not cause harmful interference, and (2) this device must accept any interference received, including interference that may cause undesired operation.

IMPORTANT SAFETY INSTRUCTIONS

WARNING

To reduce the risk of SEVERE INJURY or DEATH:

1. READ AND FOLLOW ALL WARNINGS AND INSTRUCTIONS.
2. ALWAYS keep remote controls out of reach of children. NEVER permit children to operate or play with door control push buttons or remote controls.
3. ONLY activate door when it can be seen clearly, it is properly adjusted and there are no obstructions to door travel.
4. ALWAYS keep door in sight until completely closed. NO ONE SHOULD CROSS THE PATH OF THE MOVING DOOR.
5. NO ONE SHOULD GO UNDER A STOPPED, PARTIALLY OPENED DOOR.
6. If possible, use manual release handle to disengage door ONLY when door is CLOSED. Weak or broken springs or unbalanced door could result in an open door falling rapidly and/or unexpectedly.
7. NEVER use manual release handle unless doorway is clear of persons and obstructions.
8. After ANY adjustments are made, the entrapment protection device MUST be tested.
9. Entrapment Protection device MUST be tested every month.
10. ALWAYS KEEP DOOR PROPERLY BALANCED. An improperly balanced door may not reverse when required and could result in SEVERE INJURY or DEATH.
11. ALL repairs to cables, spring assemblies and other hardware, ALL of which are under EXTREME tension, MUST be made by a trained door systems technician.
12. ALWAYS disconnect electric power to door operator BEFORE making ANY repairs or removing covers.
13. **SAVE THESE INSTRUCTIONS.**

ADJUSTMENT

ADJUST THE LIMITS

WARNING

To avoid **SERIOUS** personal **INJURY** or **DEATH** from electrocution:

• Disconnect electric power **BEFORE** performing **ANY** adjustments or maintenance.

1 Depress retaining plate.

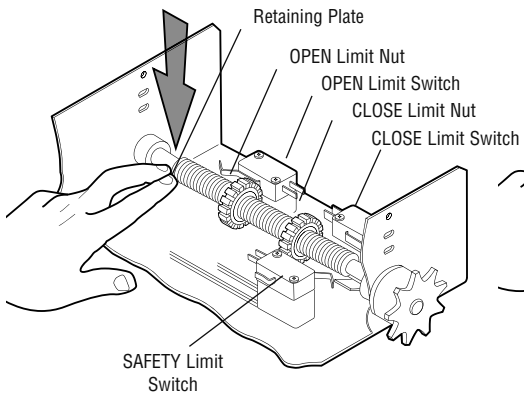

2 Adjust OPEN limit.

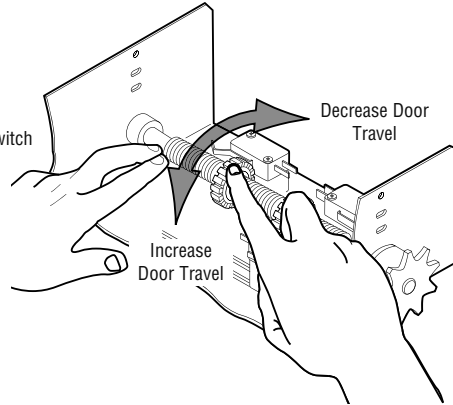

3 Adjust CLOSE limit.

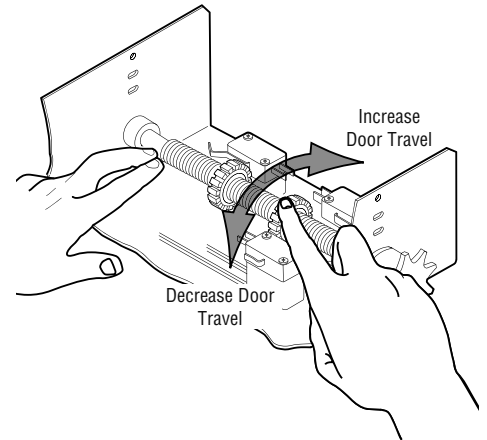

NOTE: When retaining plate is released, verify that the retaining plate is fully seated with the notches of the limit nut.

ADJUST THE CLUTCH

FOR MODELS MJ, MH, AND MHS ONLY

- 1** Apply power to operator.
- 2** Turn clutch nut to release tension.
- 3** Re-tighten nut until there is just enough tension to permit smooth operation.
- 4** Replace cotter pin. Bend ends of cotter pin to secure clutch nut.

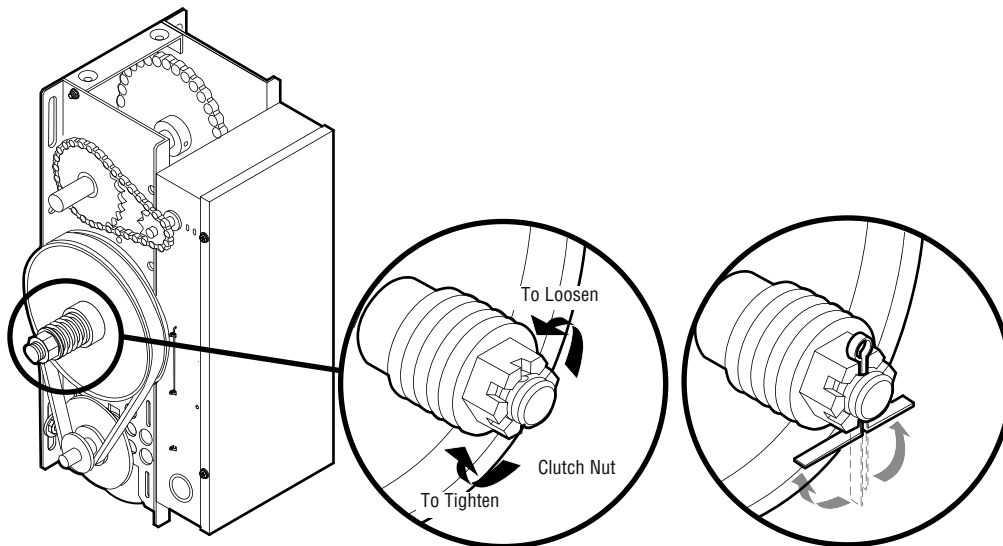

ENTRAPMENT PROTECTION

LIFTMASTER MONITORED ENTRAPMENT PROTECTION (LMEP)

IMPORTANT INFORMATION ABOUT THE LIFTMASTER MONITORED ENTRAPMENT PROTECTION DEVICES

A LiftMaster Monitored Entrapment Protection (LMEP) device is required for most wiring types. The operator comes standard with the photoelectric sensors model CPS-U, additional entrapment devices are available for purchase (see accessories). If a LiftMaster Monitored Entrapment Protection device is not installed, constant pressure to close will be required from the control station.

When properly connected and aligned, the photoelectric sensors will detect an obstruction in the path of its invisible light beam. If an obstruction breaks the light beam while the door is closing, the door will stop and typically reverse to the full open position.

The photoelectric sensors must be installed facing each other across the door, no more than 6" (15 cm) above the floor.

Each photoelectric sensor has an LED that will glow steady when the sensor is properly connected and aligned. The LEDs on both photoelectric sensors will flicker rapidly when obstructed or misaligned.

WARNING

To prevent possible **SERIOUS INJURY** or **DEATH** from a closing door:

- Be sure power is not connected to the door operator **BEFORE** installing the photoelectric sensor.
- The door **MUST** be in the fully opened or closed position **BEFORE** installing the LiftMaster Monitored Entrapment Protection device.

To prevent **SERIOUS INJURY, DEATH, ENTRAPMENT,** or **PROPERTY DAMAGE:**

- Correctly connect and align the photoelectric sensor.
- Install the photoelectric sensor beam **NO HIGHER** than 6" (15 cm) above the floor.
- This is a required safety device for B2, TS, T, and FSTS wiring types and **MUST NOT** be disabled. For D1, C2, and E2 wiring the installation of an entrapment device is recommended.
- LiftMaster Monitored Entrapment Protection devices are for use with LiftMaster Commercial Door Operators **ONLY**. Use with **ANY** other product voids the warranty.
- If an edge sensor is being used on a horizontal slide door, then place one or more edge sensors on both the leading and trailing edge.
- If an edge sensor is being used on a vertically moving door, then place one or more edge sensors on the bottom edge of the door.

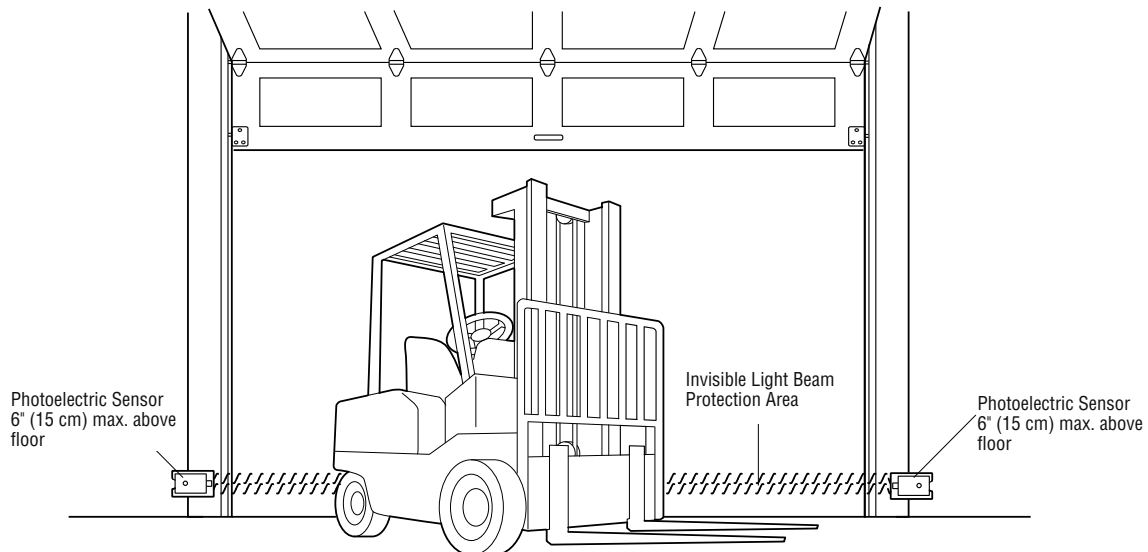

ENTRAPMENT PROTECTION

INSTALL THE PHOTOELECTRIC SENSORS (PROVIDED)

The following instructions show recommended assembly of the bracket(s) and "C" wrap based on the wall installation of the photoelectric sensors on each side of the door or on the door tracks themselves. There are also alternate mounting methods which may fit your installation requirements better.

Make sure the wraps and brackets are aligned so the photoelectric sensors will face each other across the door.

- 1 Fasten the "C" wraps to the mounting brackets having square holes, using hardware shown.

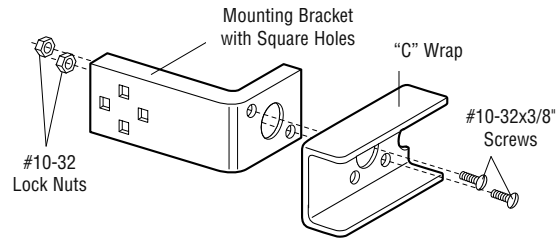

WALL INSTALLATION

- 2 Connect each assembly to a slotted bracket, using the hardware shown. **Note alignment of brackets for left and right sides of the door.**
- 3 Finger tighten the lock nuts.
- 4 Use bracket mounting holes as a template to locate and drill (2) 3/16" diameter pilot holes on both sides of the garage door, 4-6 inches (10-15 cm) above the floor. Do not exceed 6 inches (15 cm).
- 5 Attach bracket assemblies with 1/4"x1-1/2" lag screws.
- 6 Adjust right and left side bracket assemblies to the same distance out from mounting surface. Make sure all door hardware obstructions are cleared. Tighten the nuts securely.

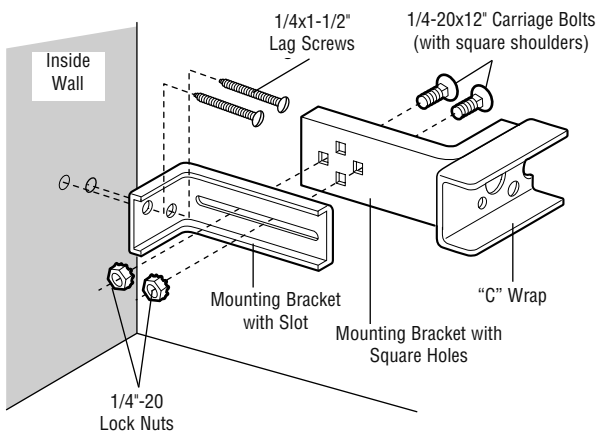

DOOR TRACK INSTALLATION

- 2 Discard slotted bracket. Drill 3/8" holes in each track and fasten securely with hardware.

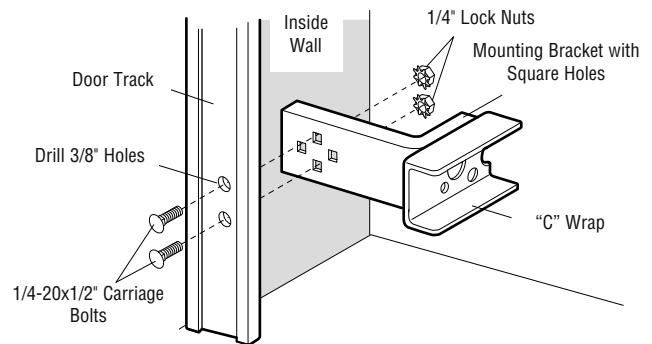

ALTERNATE WALL INSTALLATION

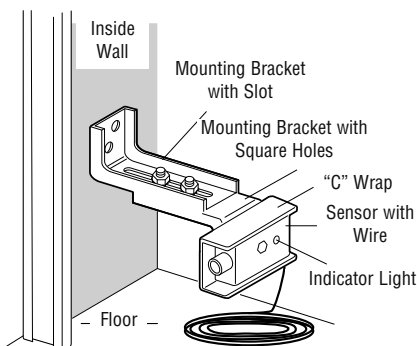

ALTERNATE FLOOR INSTALLATION

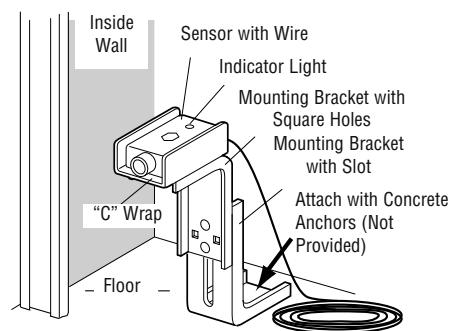

ENTRAPMENT PROTECTION

MOUNT THE PHOTOELECTRIC SENSORS (PROVIDED)

- 1** Center each sensor in the bracket with the lenses pointing toward each other across the door.
- 2** Attach the sensors to the brackets with the provided hardware. Finger tighten the *receiving sensor* wing nut. Securely tighten the *sending sensor* wing nut.
- 3** Run the wires from both sensors to the operator. Use insulated staples to secure wire to the wall and ceiling.
- 4** Connect the sensor wires to the operator.

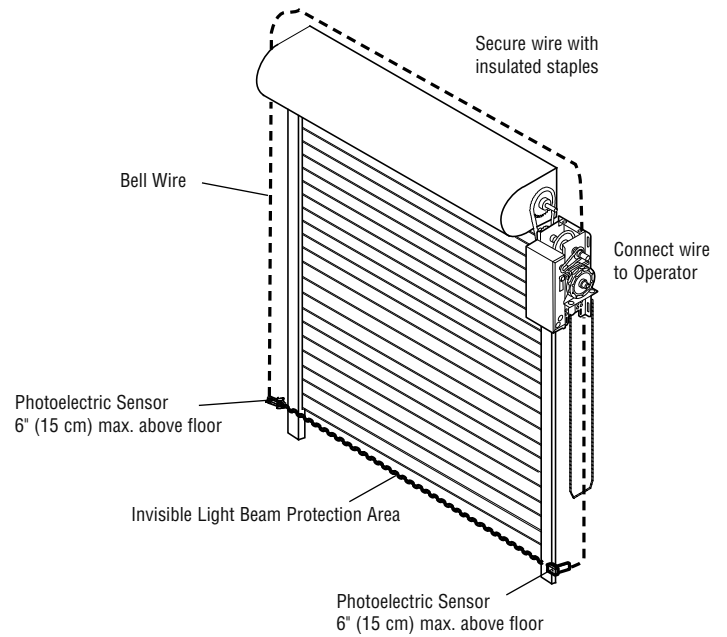
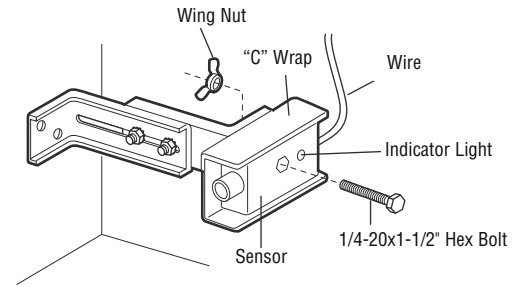

ENTRAPMENT PROTECTION WIRING OPTIONS

PRIMARY INSTALLATION: CPS-U PHOTOELECTRIC SENSORS (PROVIDED)

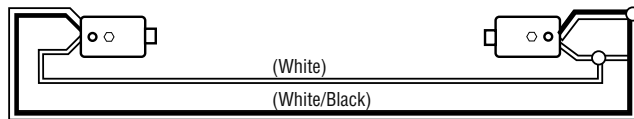

NOTE: When installing model CPS-UN4, connect the brown wire to terminal 1 and the blue wire to terminal 2.

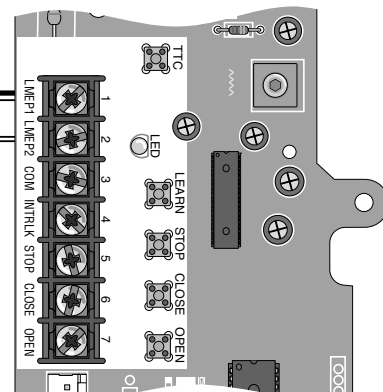

ENTRAPMENT PROTECTION

ENTRAPMENT PROTECTION WIRING OPTIONS

ALTERNATE INSTALLATIONS:

CPS-U PHOTOELECTRIC SENSOR WITH 2-WIRE SENSING EDGE

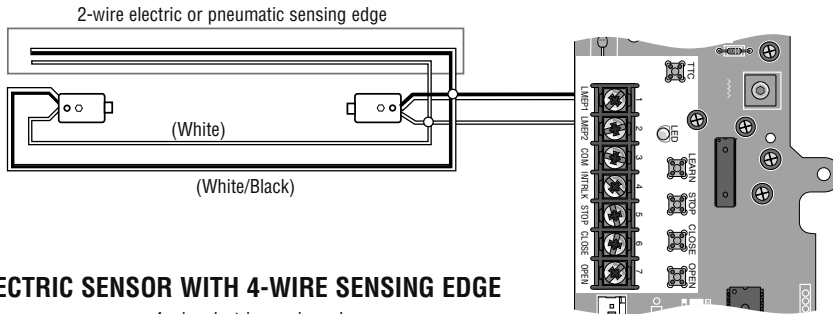

CPS-U PHOTOELECTRIC SENSOR WITH 4-WIRE SENSING EDGE

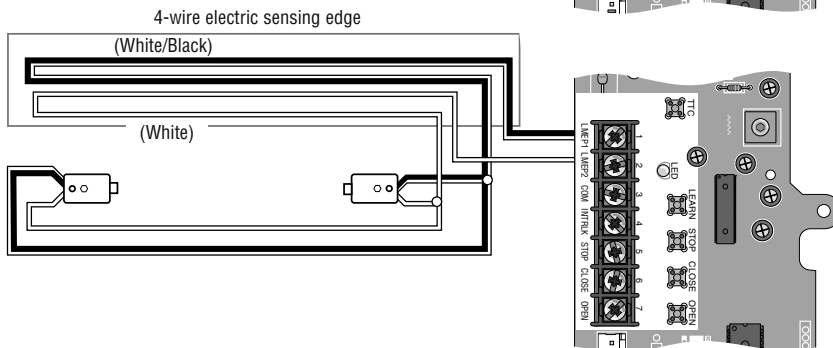

2-WIRE ELECTRIC OR PNEUMATIC SENSING EDGE (B2 NOT AVAILABLE)

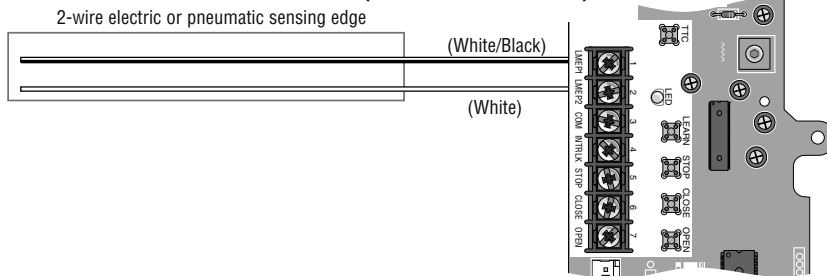

LOGIC BOARD LAYOUT

ITEM	DESCRIPTION	FUNCTION
1	Open Button	Open Door
2	Close Button	Close Door
3	Stop Button	Stop Door
4	Learn Button	Programs the remote controls and performs additional programming
5	Timer-to-Close Button	Programs the Timer-to-Close
6	Purple Wire Antenna	Primary Antenna
7	Auxiliary Antenna Connection	For use with external antenna kit -EXT-ANT. Not Provided
8	LED	Used during programming and diagnosing error codes
9	Field Wiring Terminal	Field wiring connections
10	Factory Wiring Connector	Factory wiring harness connection

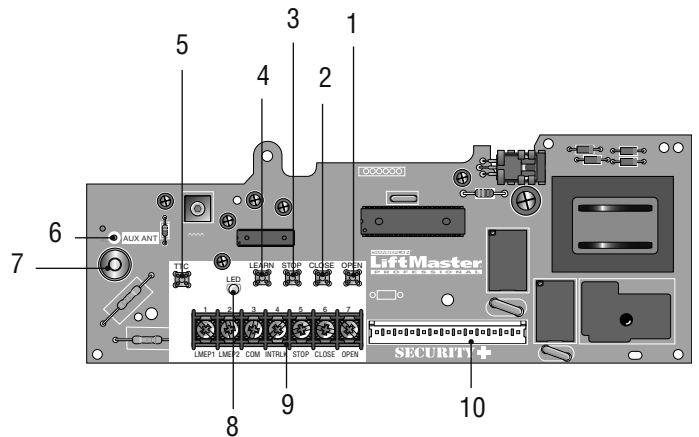

BASIC PROGRAMMING

DETERMINE THE WIRING TYPE

The functionality of this operator is based on the wiring type. The operator is shipped from the factory in standard C2 wiring type (factory default). LIFTMASTER MONITORED ENTRAPMENT PROTECTION (LMEP) DEVICE IS REQUIRED.

A LiftMaster Entrapment Protection (LMEP) device is **required** for the following wiring types.

NOTES:

- The LED on the logic board will blink once when in C2 and twice when in B2.
- The operator will automatically convert to B2 wiring when Monitored Entrapment Protection Device is installed. If the Monitored Entrapment Protection Device is removed, the operator will go into a Restricted Close mode**. Turn power OFF and ON to reset wiring type.

** Restricted close mode requires a constant pressure close command. The operator will begin closing after a 5 second delay and will continue to close to the close limit switch. The operator will stop if the pressure to close is released before reaching the close limit.

RECOMMENDED INSTALLATION: B2 WIRING TYPE WITH MONITORED ENTRAPMENT PROTECTION DEVICE

- Momentary contact to open, close and stop.
- Open override that reverses when closing by any opening device.
- Wiring for entrapment protection device to reverse.
NOTE: The operator will automatically convert to B2 wiring when Monitored Entrapment Protection Device is installed. (See accessories page for Monitored Entrapment Protection Devices.)
- **Timer-to-Close (TTC) feature available.**

No Programming Required

MONITORED ENTRAPMENT PROTECTION DEVICE

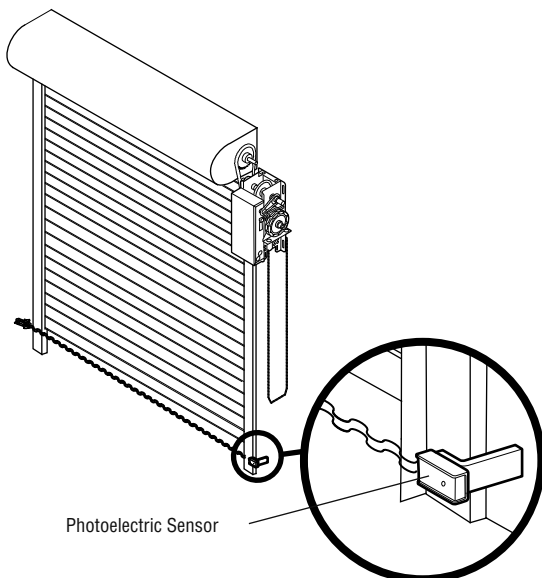

BASIC PROGRAMMING

DETERMINE THE WIRING TYPE

ALTERNATE INSTALLATION: C2 WIRING TYPE WITH MONITORED ENTRAPMENT PROTECTION DEVICE

- Momentary contact to open and stop with constant pressure to close.
- Open override that reverses when closing by any opening device.
- Wiring for entrapment protection device to reverse.
NOTE: The operator will automatically convert to B2 wiring when Monitored Entrapment Protection Device is installed. (See accessories page for Monitored Entrapment Protection Devices.)
- Timer-to-Close (TTC) feature not available.

MONITORED ENTRAPMENT PROTECTION DEVICE

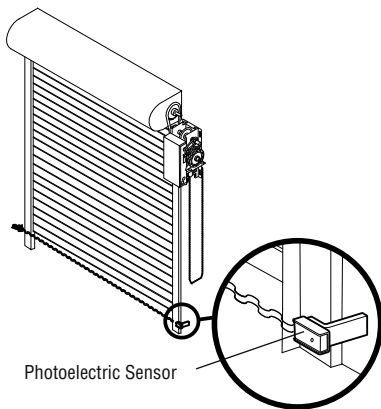

To Program:

- 1 Press and hold the LEARN and CLOSE buttons until the LED goes out (approximately 3 seconds).

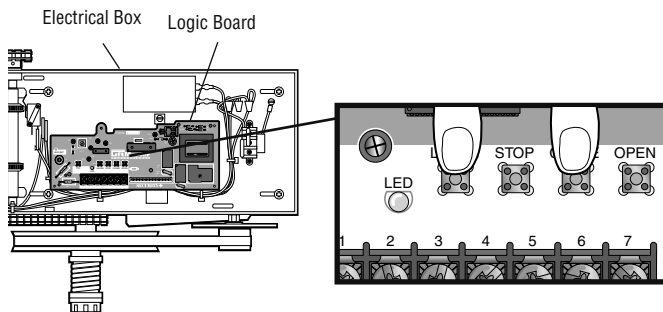

To Reset to B2 with Monitored Entrapment Protection Device:

- 1 Press and hold the LEARN and STOP buttons until the LED goes out (approximately 3 seconds).

REMOTE CONTROLS

RADIO OPERATION					
MODE	OPEN	CLOSE	STOP	REVERSE WHILE CLOSING	TTC RESET
B2	X	X	X	X	
B2 with TTC	X	X (3-button remote)	X	X	X when open
C2	X		X	X	

ALTERNATE INSTALLATION: C2 WIRING TYPE WITHOUT MONITORED ENTRAPMENT PROTECTION DEVICE (FACTORY DEFAULT)

- Momentary contact to open and stop with constant pressure to close.
- Open override that reverses when closing by any opening device.
- Wiring for entrapment protection device to reverse.
NOTE: The operator will automatically convert to B2 wiring when Monitored Entrapment Protection Device is installed. (See accessories page for Monitored Entrapment Protection Devices.)
- Timer-to-Close (TTC) feature not available.

NON-MONITORED ENTRAPMENT PROTECTION DEVICE

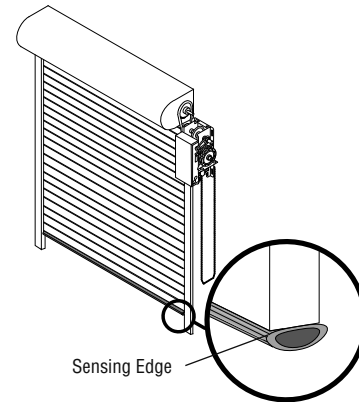

Reset to FACTORY DEFAULT (C2) without Monitored Entrapment Protection Device:

- 1 Remove any monitored entrapment protection devices.
- 2 Press and hold the LEARN and STOP buttons until LED goes out (approximately 3 seconds).

BASIC PROGRAMMING

REMOTE CONTROLS

⚠ WARNING

To prevent possible SEVERE INJURY or DEATH:

- Install a LiftMaster Monitored Entrapment Protection (LMEP) device.
- NEVER permit children to operate or play with door control push buttons or remote controls.
- Activate door ONLY when it can be seen clearly, is properly adjusted and there are no obstructions to door travel.
- ALWAYS keep door in sight until completely closed. NEVER permit anyone to cross the path of closing door.

Built in 315 MHz radio receiver permits as many as 20 Security+® remote controls or dip switch remote controls in any combination.

SINGLE BUTTON REMOTE CONTROL

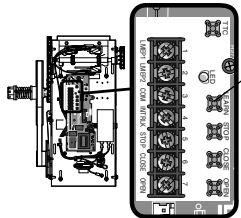
1  Press and release the LEARN button (LED will light).

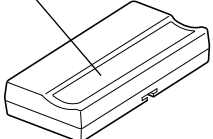
2  Press and hold the button on the remote control until the LED flashes rapidly, then release to complete programming (LED will go out).

Repeat steps 1 and 2 for additional remote controls.

TO ERASE ALL REMOTE CONTROLS

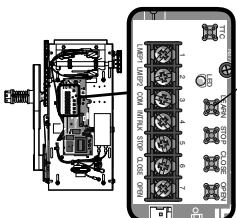
1  Press and hold the LEARN button (over 5 seconds) until the LED goes out. All programmed remote controls will be erased.

3-BUTTON REMOTE CONTROL TO OPERATE AS A WIRELESS 3-BUTTON CONTROL STATION

NOTE: The feature will use 3 of the 20 memory channels in the operator.

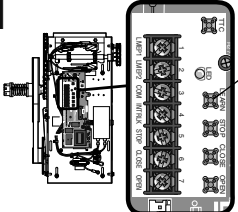
1  Press and hold the LEARN button (LED will light).

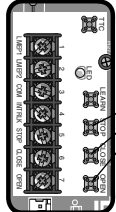
2  Press the desired button on the logic board (OPEN, CLOSE or STOP). Release both buttons.

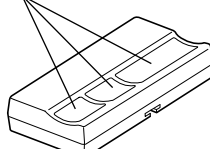
3  Press and hold the desired button of the remote control until LED flashes rapidly, then release.

Repeat steps 1 through 3 to program additional buttons.

TIMER-TO-CLOSE (TTC)

Timer-to-Close feature enables the operator to close from the open limit after a preset time, adjustable from 5 to 60 seconds. **Requires LiftMaster Monitored Entrapment Protection (LMEP) device.**

TO PROGRAM

Begin with door in fully closed position.

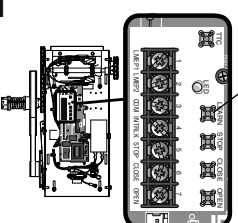
1  Press and release the LEARN button (LED will light).

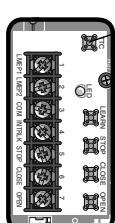
2  Press and release the TTC button.

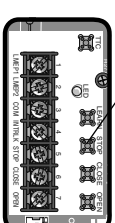
3  Every press and release of the STOP button will add 5 seconds to the Timer-to-Close. Example: 30 second TTC = 6 presses of the STOP button.

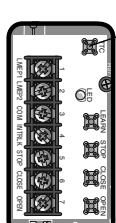
4  Press and release the TTC button to exit programming mode. The LED will flash once per 5 seconds of timer setting.

The TTC will become active after completion of the next open cycle. **NOTE:** The LED does not indicate that timer is running.

TO VERIFY TIMER-TO-CLOSE (TTC) SETTING

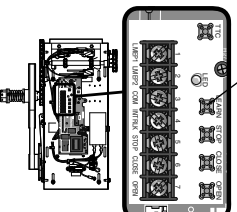
1  Press and hold the LEARN button (LED will light).

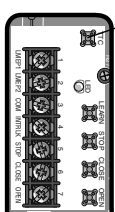
2  Press and release the TTC button.

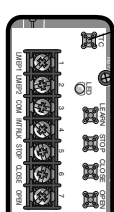
3  Press and release the TTC button a second time. The LED will flash once per 5 seconds of timer setting.

BASIC PROGRAMMING

TIMER-TO-CLOSE (TTC)

CLEAR THE TIMER-TO-CLOSE (TTC)

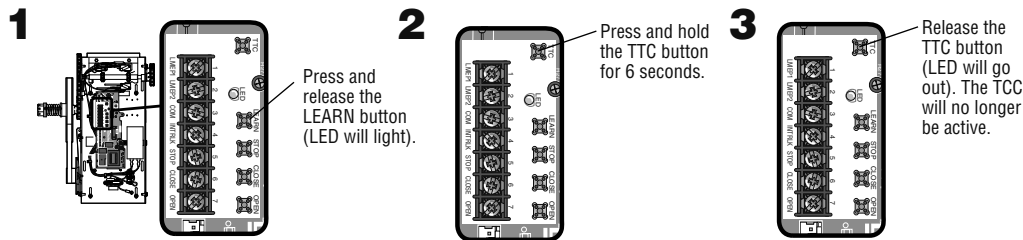

TIMER DEFEAT

The TTC can be temporarily disabled by pressing a STOP button. TTC will become enabled after the next open command.

TESTING

WARNING

To avoid **SERIOUS** personal **INJURY** or **DEATH**:

- Disconnect electric power **BEFORE** performing **ANY** adjustments or maintenance.
- **ALL** maintenance **MUST** be performed by a trained door systems technician.

Turn on power, LED will flash 4 times on power up. Test all controls and entrapment protection devices to make sure they are working properly. It may be necessary to refer back to the Adjustment section for adjustment of the limits.

IMPORTANT NOTES:

- Do not leave power to the operator on unless all entrapment protection devices have been tested and are working properly.
- Be sure you have read and understand all safety instructions included in this manual.
- Be sure the owner or person(s) responsible for operation of the door have read and understand the safety instructions, know how to electrically operate the door in a safe manner and how to manually disconnect the door from the operator.

TEST 3-BUTTON CONTROL STATION

- 1** Press OPEN button. (The door should move in the open direction.)
- 2** Press STOP button. (The door should stop.)
- 3** Press CLOSE button. (The door should move in the close direction.)
- 4** Release CLOSE button. Door should stop if in C2 mode. (The door should continue closing if in B2 mode.)
- 5** Press STOP button. (The door should stop.)

TEST LIMIT ADJUSTMENT

- 1** Press OPEN button. (The door should open.)
- 2** Allow the door to fully open.
- 3** Press CLOSE button. (The door should close.)
- 4** Allow the door to fully close.

If the limits are not set properly, remove power and adjust limits (refer to Adjustment section).

TEST THE ENTRAPMENT PROTECTION DEVICES

- 1** Open the door.
- 2** Place an obstruction in the path of the photoelectric sensors or sensing edge.
- 3** Press the CLOSE button. The door should not close if photoelectric sensors are installed. The door should close to obstruction and reverse if sensing edge is installed.
- 4** Remove the obstruction.
- 5** Press CLOSE button. Door should close.

If door did not reverse from obstruction, check entrapment protection devices.

TEST REMOTE CONTROL

Requires B2 wiring type and compatible LiftMaster remote control. In C2 wiring the remote control will open the door only.

- 1** Press remote control button.
- 2** Door should open. Allow the door to fully open.
- 3** Press remote control button.
- 4** Door should close. Allow door to fully close.

EMERGENCY DISCONNECT

WARNING

To prevent possible **SERIOUS INJURY** from a moving chain:

- **DISCONNECT** electric power to the operator **BEFORE** manually operating your door.
- If possible, use emergency disconnect **ONLY** when door is **CLOSED**. Weak or broken springs or unbalanced door could result in an open door falling rapidly and/or unexpectedly.
- **NEVER** use emergency disconnect unless doorway is clear of persons and obstructions.

This operator has provisions for manually operating the door in case of emergency or power failure. Refer to the appropriate instructions below for your model operator.

MODEL MH

These operators are equipped with a manual hoist. An electrical interlock will disable the electrical controls when the hoist is used.

- 1** Pull the disconnect chain (sash chain) to engage the hoist mechanism. The disconnect chain may be locked in position by slipping the end through the keyhole of the chain keeper mounted on the wall.
- 2** Operate the door in the desired direction by pulling on one side or the other of the continuous loop hoist chain.
- 3** The disconnect chain must be released from the chain keeper before the door will operate again electrically.

MODEL MHS

The MHS operator includes both a floor level disconnect sash chain to disconnect the door from the door operator that allows manual push up operation and an additional sash chain to engage the manual chain hoist that also electrically disables the operator controls.

- 1** Refer to Model MH instructions for hoist operation.
- 2** Refer to Model MJ instructions for manual operation.

When the manual chain hoist sash chain is engaged, electrical operation will not function.

ELECTRICAL INTERLOCK WITH HOIST FOR MODELS MH AND MHS

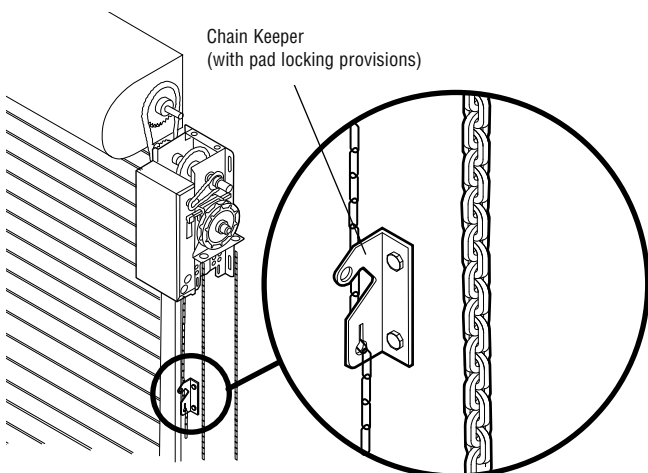

MODELS MJ AND MGJ

This operator has a floor level disconnect chain to disconnect the door from the door operator.

- 1** To disengage, pull the chain and secure in the disengaged position by slipping the end through the keyhole bracket mounted on the wall. Or if emergency egress device is used, pull handle to disengage operator from door.
- 2** The door may now be pushed up or pulled down manually.
- 3** Release the disconnect chain or reset the emergency egress device to operate the door again electrically.

EMERGENCY DISCONNECT FOR MODELS MJ

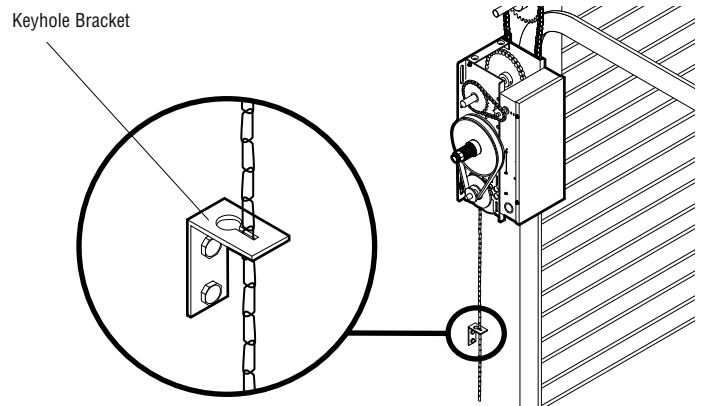

TROUBLESHOOTING

Technical Support 1-800-528-2806

CONDITION	POSSIBLE CAUSE	FIX
OPERATOR WILL NOT RESPOND TO ANY COMMANDS	A) No power	➤ Verify primary line voltage (120 Vac, 60 Hz) is present at terminals L1 & L2. The LED will flash when power is present.
	B) Stop circuit not complete	➤ Verify Stop Button input (terminals 3 & 5) is properly wired and stop button is not stuck.
	C) Stuck button on 3-button control station	➤ Verify that all buttons are actuating freely and releasing properly.
	D) Interlock input activated	➤ Verify jumper is located at terminals 3 & 4 if interlock is not present. ➤ Verify interlock is properly wired and not activated.
	E) Motor overload tripped	➤ Overload is internal within motor. Allow to cool and retry.
	F) Accessory failure	➤ Attempt to close by holding the CLOSE button for more than 5 seconds. If door closes, check accessory for proper wiring, polarity, connections or damage. ➤ Verify photoelectric sensors are aligned or sensing edge is not activated.
	G) Possible component failure	➤ Call Technical Support for assistance.
OPERATOR MAKES NOISE BUT DOOR DOES NOT MOVE	A) Clutch slipping	➤ Adjust clutch, see ADJUSTMENT section.
	B) Brake not releasing (if present)	➤ Verify brake assembly operation and wiring.
	C) Door operation problem	➤ Disconnect trolley and check door for proper operation.
OPERATOR MOVES IN THE WRONG DIRECTION	OPEN and CLOSE button wiring connection reversed	➤ Check 3-button control wiring.
DOOR DRIFTS AFTER OPERATOR STOPS	A) Door not balanced properly	➤ Disconnect trolley assembly and check door for proper operation.
	B) Clutch slipping	➤ Adjust clutch, see ADJUSTMENT section.
	C) Brake not functioning properly	➤ Check brake mechanism to ensure brake lever is free and brake pads are engaging the brake disc.
DOOR OPENS/CLOSES TOO FAR	Limits not adjusted properly	➤ Adjust limits. See ADJUSTMENT section.
DOOR REVERSES UNEXPECTEDLY	Intermittent Entrapment Protection Device activation	➤ Check all connections.
TTC NOT FUNCTIONING	A) Monitored Entrapment Protection Devices	➤ Check all connections. Verify photoelectric sensors are not blocked and the sensing edge is not activated.
	B) TTC temporarily disabled	➤ Close and Open the door. TTC will be re-enabled.
	C) TTC not programmed properly	➤ Reprogram TTC. See PROGRAMMING TTC section.
RADIO FUNCTIONALITY	NOTE: Built in radio receiver compatible with all LiftMaster 315 MHz remote control devices.	
NO RESPONSE	A) Remote control is not programmed	➤ See PROGRAMMING REMOTE CONTROLS section.
	B) Remote control not compatible	➤ Obtain qualified LiftMaster remote control device.
	C) Low battery	➤ Replace battery.
REMOTE CANNOT BE LEARNED	A) Low battery	➤ Replace battery.
	B) Remote control not compatible	➤ Obtain qualified LiftMaster remote control device.
POOR RADIO RANGE	A) Low battery in remote	➤ Replace battery.
	B) Antenna not configured	➤ See SETUP RADIO ANTENNA.
	C) Ambient radio interference or building structural issue	➤ Use EXTERNAL ANTENNA kit (see ACCESSORIES page).

TROUBLESHOOTING

The status of the operator can be determined by counting the number of flashes of the LED on the logic board.

DIAGNOSTIC LED TABLE		
# OF LED FLASHES	STATUS	FIX
1	System OK. Operating in C2 mode	None
2	System OK. Operating in B2 mode	None
3	Stuck CLOSE button	Check for stuck close button or shorted close wire
4	Monitored Entrapment Protection Device failure	Check for: 1) Misaligned or blocked Photoelectric Sensors. 2) Issue with Monitored Sensing Edge and/or wiring.
5	Incorrect motor direction	Reverse the yellow and red motor wires on the capacitor.
6	Maximum run timer has timed out (Maximum run time = 90 seconds)	Check clutch adjustment. Door height or speed may exceed the range the operator can travel. Call Technical Support for assistance.
7	Logic Board Failure	Replace Logic Board. NOTE: It is normal for the logic board LED to flash 4 times when power is applied or cycled to the operator. (Not a logic board failure.)

DIAGRAM

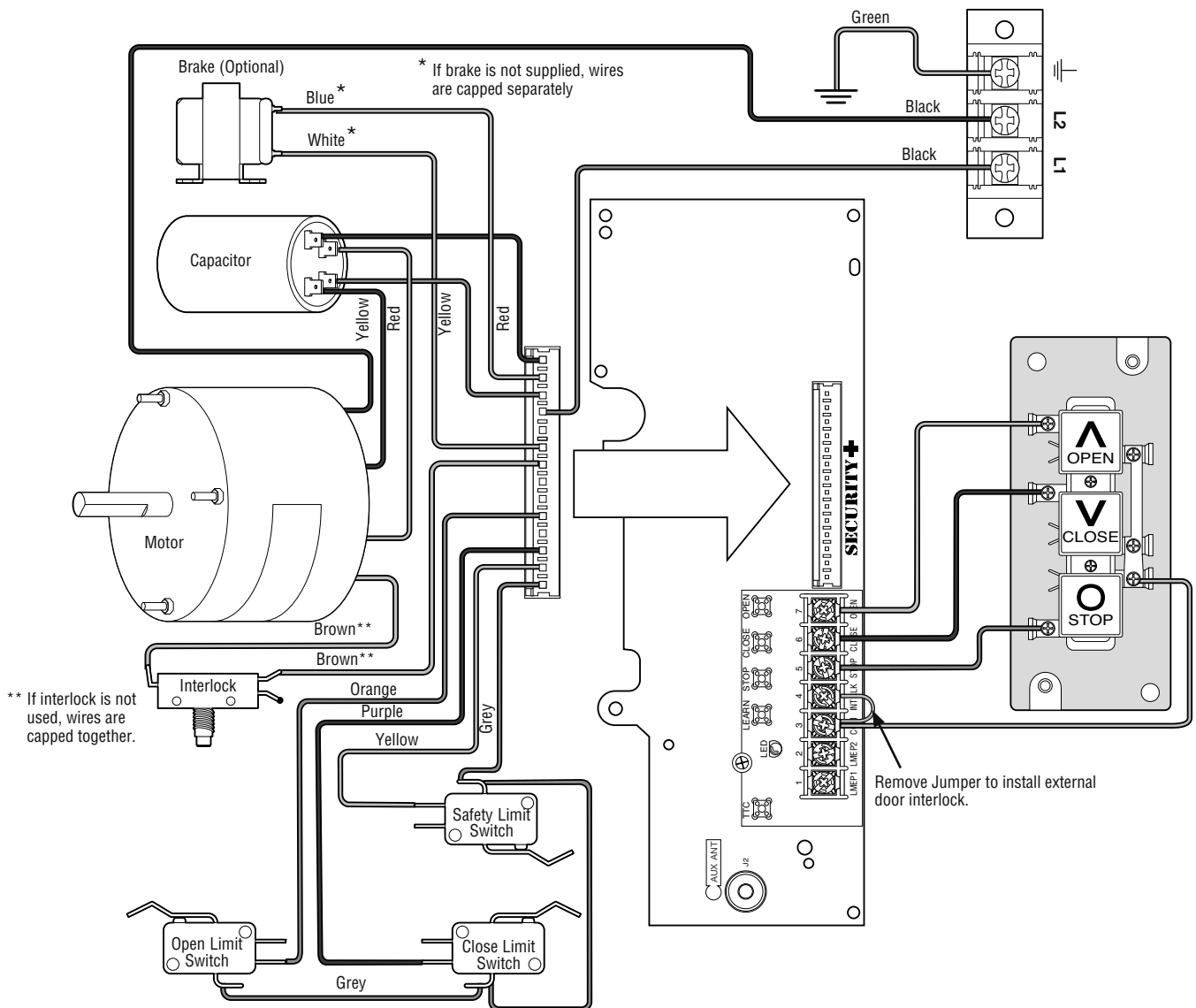

ACCESSORIES

REMOTE CONTROLS 315 MHZ

LiftMaster offers a variety of **SECURITY+** Remote Controls for your application needs. Single to 4-Button, visor or key chain. Contact your authorized dealer.



371LM

1-Button **SECURITY+** Remote Control:

Includes visor clip.

373LM

3-Button **SECURITY+** Remote Control:

Includes visor clip.

333LM

3-Button Tri-Colored Dip Switch Remote Control:

Open/Close/Stop functionality. Includes visor clip.

WPB1LM3

Wireless Single Push Button Control **SECURITY+**:

Rugged composite housing. (Wireless controls cannot be used in place of hard wired controls.)



WPB3LM3

Wireless 3 Button Control Station **SECURITY+**:

Rugged composite housing. (Wireless controls cannot be used in place of hard wired controls.)



WKP5LM3 (5 4-digit entry codes)

WKP250LM3 (250 4-digit entry codes)

Wireless Access Control Keypads **SECURITY+**:

Rugged composite housing. (Wireless controls cannot be used in place of hard wired controls.)



CONTROL STATIONS

02-102

2-Button Control Station:

Steel enclosure.

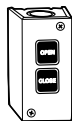

02-103

3-Button Control Station:

Steel enclosure.

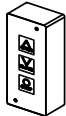

02-109

Key Control Station:

Indoor flush mount, NEMA 1.



CHAIN TENSIONERS

For Jackshaft Type Operators

71-6023

Chain Tensioner:

For 1" shafts

71-6125

Chain Tensioner:

For 1-1/2" shafts

ENTRAPMENT PROTECTION DEVICES

CPS-UN4

Commercial Protector System:

LiftMaster Monitored Entrapment Protection (LMEP) provides protection on doors up to 45' wide. NEMA-4 rated.



CPS-U

Commercial Protector System:

LiftMaster Monitored Entrapment Protection (LMEP) provides protection on doors up to 30' wide.

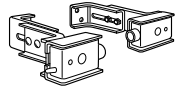

CPS-EI

Monitored Sensing Edge Interface:

Requires 4-wire monitored sensing edge.

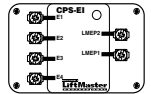

65ME1234

Miller ME123 4-Wire Monitored Safety Edge:

For sectional or rolling doors.

65ME110

Miller ME110 4-Wire Monitored Safety Edge:

For rolling grilles and counter shutters.

MOUNTING BRACKETS

10-12360

Mounting Brackets:

Angle mounting bracket, Painted steel, for MJ, MH, and MHS.

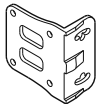

10-9095

Medium Duty Angle Mounting Bracket:

Heavy-gauge steel bracket. May be welded. For use with MJ, MGJ, and MH operators.

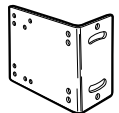

ANTENNA

EXT-ANT

Antenna:

External kit for medium duty.

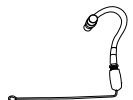

86LM (15')

86LMT (25')

Antenna Extension Kit:

The antenna extension kit can be used with EXT-ANT for maximum radio receiver range.

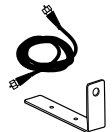

FIELD MODIFICATION KITS

71MLSBC

Single Button Control:

Provides additional input for Single Button Control functionality. Input functions as Close input when the operator is stopped at the Open limit. Input functions as Open input at all other times. Also used with external radio controls.

71 MLMOTION

Door-In-Motion:

Provides dry contact and a terminal block with contacts switched to power an auxiliary device while the door is in motion.

CONTROL CONNECTION DIAGRAM

IMPORTANT NOTES:

1. The 3-Button Control Station provided must be connected for operation.
2. If a STOP button is not used, a jumper must be placed between terminals 3 and 5.
3. If INTERLOCK is not used a jumper must be placed between terminals 3 and 4.
4. When adding accessories, install them one at a time and test each one after it is added to ensure proper installation and operation with the Commercial Door Operator.

